



# Johndec Engineering



## CHEMCO Chemical Resistant Centrifugal Plastics Fan – Direct Drive Series



*Superior Quality Plastics Fans Engineered for Extreme Chemical Environments & Internationally Renowned*





## Johndec CHEMCO Chemical Resistant Fan Range

The Johndec CHEMCO range of fans are developed to handle heavy corrosive fumes, vapours, contaminated air and aggressive gases. Casing and impeller of thermoplastics such as PP, PE, PVC, PVDF or GRP. Can be blended with composites to overcome high temperature, flame retardant resistant, ultraviolet or Electrostatic Discharge protection. Tested and rated in accordance with BSI and AMCA standards. Noise accordance to DIN 45635. Balanced in accordance with Grade G2.5 of BS 5625 Part 1 (1979). All data is available for downloading. For further information on the complete Johndec CHEMCO range please contact our Sales Office.

FAN MODEL RANGE	DESCRIPTION	DRIVE ARRANGEMENTS	
		DIRECT	BELT
CHEM75 to 110	Small compact medium pressure chemical resistant plastic centrifugal fan	✓	X
CHEM125 to 400	Medium pressure chemical resistant plastic centrifugal fan	✓	✓
CHEM450 to 710	Medium pressure chemical resistant plastic centrifugal fan	✓	✓
CHEM800 to 1250	Medium pressure chemical resistant plastic centrifugal fan	✓	✓
CHEM LS5 to 41	High pressure chemical resistant plastic centrifugal fan	✓	✓
T-CHEM 100 to 315	Turbo pressure chemical resistant plastic fan centrifugal fan (Up to 10,000 Pa static)	✓	✓

### Johndec Chemco Fan Selection Programme

This is a great tool to make selection of the right Johndec Chemco fan easy, just enter in the required volume and pressure drop and the programme will do the rest. For a copy of this software please contact our sales office

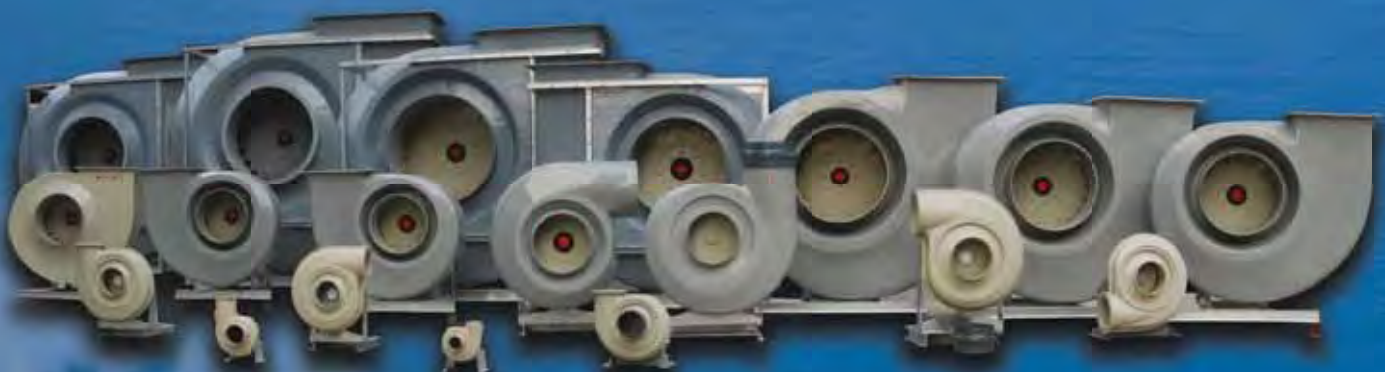
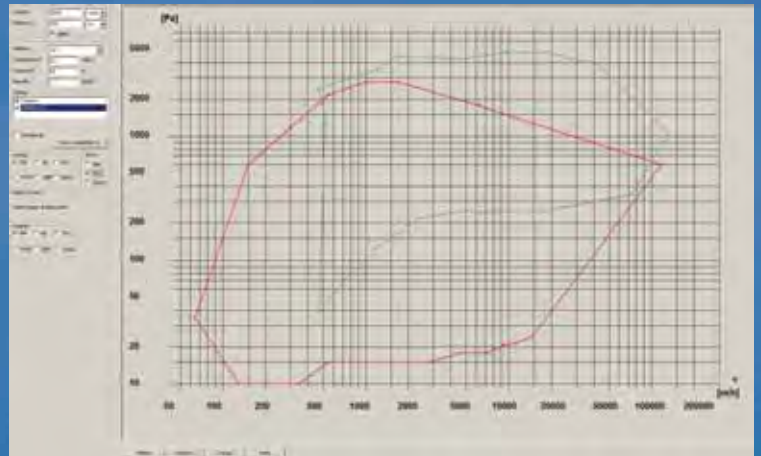
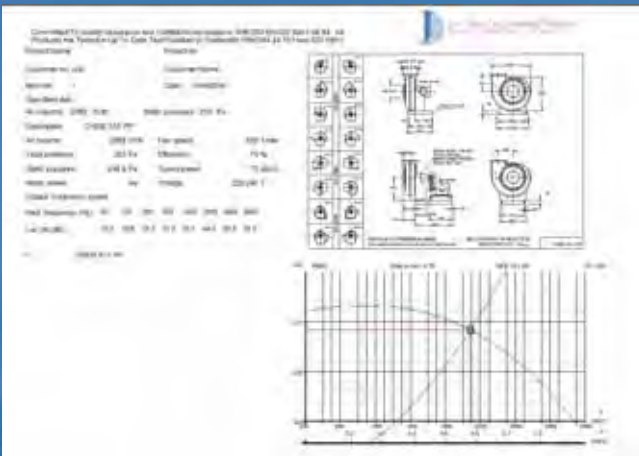

---

Inhaltsverzeichnis . . . . .	1	Table of Content . . . . .	1
Technische Informationen . . . . .	2	Technical Information. . . . .	2
CHEMCO = chemisch beständige Kunststoff-Lüfter .	2	CHEMCO = chemical resistant plastic fan . . . . .	2
Typenschlüssel . . . . .	2	Fan type code . . . . .	2
Konstruktion der chemisch beständigen Radiallüfter .	2-3	Chemical Resistant Centrifugal Plastic Fan Design . .	2-3
. . . . .		. . . . .	
CHEM 75R Datenblatt . . . . .	4	CHEM 75R Specification sheet . . . . .	4
CHEM 90R Datenblatt . . . . .	5	CHEM 90R Specification sheet . . . . .	5
CHEM 90FC Datenblatt . . . . .	6	CHEM 90FC Specification sheet . . . . .	6
CHEM 110 Datenblatt . . . . .	7	CHEM 110 Specification sheet . . . . .	7
CHEM 125 Datenblatt . . . . .	8	CHEM 125 Specification sheet . . . . .	8
CHEM 160 Datenblatt . . . . .	9	CHEM 160 Specification sheet . . . . .	9
CHEM 180 Datenblatt . . . . .	10	CHEM 180 Specification sheet . . . . .	10
CHEM 200 Datenblatt . . . . .	11	CHEM 200 Specification sheet . . . . .	11
CHEM 250 Datenblatt . . . . .	12	CHEM 250 Specification sheet . . . . .	12
CHEM 315 Datenblatt . . . . .	13	CHEM 315 Specification sheet . . . . .	13
CHEM 400 Datenblatt . . . . .	14	CHEM 400 Specification sheet . . . . .	14
CHEM 75 zu CHEM 110DD Auf-und Einbau . . . . .	15	CHEM 75 to 110DD Assembly and mounting . . . . .	15
CHEM 125 zu CHEM 200DD Auf-und Einbau. . . . .	16	CHEM 125 to 200DD Assembly and mounting . . . . .	16
CHEM 250 zu CHEM 315DD Auf-und Einbau. . . . .	17	CHEM 250 to 315DD Assembly and mounting . . . . .	17
CHEM 400DD Auf-und Einbau . . . . .	18	CHEM 400DD Assembly and mounting. . . . .	18

### CHEMCO = chemisch beständige Kunststoff-Lüfter

#### Rolle

Chemco spielte eine führende Rolle bei der Herstellung von Gegenständen aus nicht rostenden und chemisch widerstandsfähigen Kunststoffen. Die Ventilatoren zeichnen sich durch einen hohen Wirkungsgrad, zuverlässiges Betriebsverhalten und hervorragende Korrosionsfestigkeit aus. Grundmerkmale sind ebenso die einfache Wartung und die Wirtschaftlichkeit.

#### Gütegrad

Chemco bietet eine komplette Baureihe wirkungsvoller rückwärts gekrümmter Radialventilatoren hoher Qualität mit sehr guter Leistung und niedrigem Geräuschpegel. Alle Ventilator-Antriebe und Zubehöre werden nach genauen Qualitätsstufen hergestellt. Es kommen nur Qualitäts-Werkstoffe zum Einsatz und alle Ventilatoren sind erprobt und geprüft nach DIN 24163 und ISO 5801.

#### Schallpegel

Um eine Bewertung entsprechend dem menschlichen Gehör zu ermöglichen wurde die A-bewertete Beschreibung des Schallpegels gemäß DIN 45635 gewählt.

Die Schallmessung erfolgt mit dem Hüllflächenverfahren gemäß DIN 45635 Teil 38 oder dem Kanalverfahren DIN 45635 Teil 9.

### Typenschlüssel

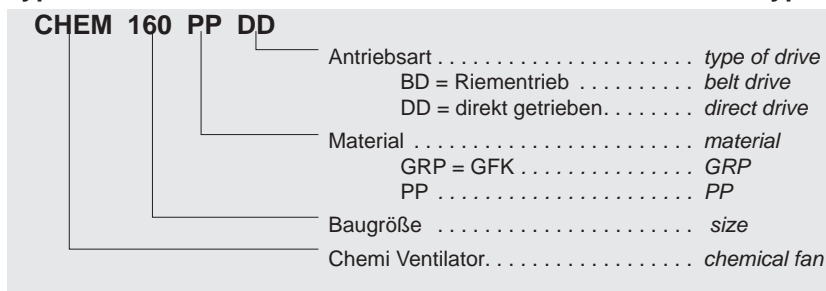

### CHEMCO = chemical resistant plastic fan

#### Role

Chemco has played a leading role in the manufacturing of equipment made from anti-corrosive and chemical resistant plastics. The fans are specially designed for high efficiency, reliability, with superior corrosion resistance quality. They are also developed to give trouble-free service, and are economical in use.

#### Quality

Chemco supply a complete range of high quality and efficient radial tip backward curve fans, which offer an excellent performance with a low noise level. All fans drive and accessories are produced to strict quality standards. Only the best quality materials are used and all fans are tested and rated in accordance with DIN 24163 and ISO 5801.

#### Sound Level

In order to make possible an assessment of sound projection adequate to human ear the A-assessed description of sound level according to DIN 45635 has been chosen.

The ascertaining of the sound power level follows the enveloping surfaces method according to DIN 45635 section 38 or the channel technique DIN 45635, section 9.

### Fan type code

### Konstruktion der chemisch beständigen Radiallüfter

#### Gehäuse

Das Ventilatorgehäuse ist entweder aus thermoplastischen Kunststoffen wie PP, PVC, PE, PVDF oder Glasfaserverstärkten Kunststoffen - Vinyl Ester Klasse (GFK oder FFK). Das Ventilatorgehäuse hat die Form einer echten Spirale und hat eine Hochleistungsansaugdüse um eine gleichmäßige Luftverteilung über die volle Laufradbreite zu erreichen.

Die kleineren Gehäuse, Typ **CHEM 75 - 315** sind vollständig aus Spritz-Kunststoff und passen sowohl für rechte als auch für linke Drehrichtung. Die Rückscheibe und Ansaugdüse, beide aus Spritzkunststoff, können leicht entfernt und getauscht werden um die Drehrichtung anzupassen oder bei Wartungsarbeiten. **CHEM 125 - 200** Ventilatorgehäuse mit Ausblasflansch werden mit chemisch beständiger Dichtung zur Vermeidung von Luftleckage geliefert. Typ **Chem75 - 110 & 250 - 315** ventilatorgehäuse haben einen runden geraden Ausblas passend zur direkten Montage eines elastischen Verbinders. Standardmaterial des Gehäuse ist PP.

Die **CHEM 400** Gehäuse sind gewöhnlich aus GFK. Die GFK Ventilatorgehäuse haben einen runden geraden Ausblas passend zur direkten Montage eines elastischen Verbinders.

#### Rückwärtsgekrümmte Radiallaufräder

Chemco Lüfterlaufräder sind einflütig mit konstanter Breite (SISW). Die Herstellung erfolgt durch Präzisions-spritzguß mit eingegossener Metallnabe und maschinell geschweißt. Sie entsprechen höchsten Qualitätsstufen und haben ausgezeichnete aerodynamische Eigenschaften.

Als Standard wird PP für das Laufrad verwendet, je nach Einsatzfall können auch Pa, PC, PVC oder PVDF Verwendung finden. Entsprechend den Anforderungen des Kunden an Hochtemperatur-, UV-Beständigkeit oder Schutz vor elektrostatischer Entladung können die Laufräder auch aus einem thermoplastisch Material vermengt mit Füllstoffen sein. Jedes Laufrad ist, nach Q2,5 (VDI 2060), statisch und dynamisch in zwei Ebenen gewuchtet. Die Radnaben sind für die Verwendung von Taper-lock-Naben vorgesehen und sind aus hochwertigen Gußplatten. Dies gewährleistet einen zuverlässigen Lauf auch bei hoher Umfangsgeschwindigkeit.

#### Ventilatorbock und Lager

Die Ventilatorböcke und Grundrahmen sind aus schweren Walzstahlprofilen hergestellt und eine Zink anwendung beendet stabilised UV-Decklack. Dies bietet besten Schutz bei widrigsten Bedingungen. Spezielle Oberflächenbehandlungen sind auf Wunsch möglich. Der Ventilator kann in verschiedene Ausblasrichtungen gedreht werden.

### Chemical Resistant Centrifugal Plastic Fan Design

#### Casing

The fan casing is constructed from thermoplastic such as PP, PVC, PE, PVDF or Glass reinforced plastic -Vinyl ester grade (GRP or FRP). The fan casing is built to a true volute form and has high efficiency inlet cone to give an even distribution of air over the full width of the runner.

The smaller range of casing, model **CHEM 75 - 315** are completely plastic injection moulded suitable for dual rotation at any position. The plastic injection moulded backplate or inlet cover can be easily removed for changing of rotation, maintenance and services. **CHEM 125 - 200** fans casing with outlet flange come with chemical resistant seal to prevent air leakage. **CHEM 75 - 110 & CHEM 250 - 315** come with round straight outlet suitable for direct connection to flexible connector. Casing usually with PP as standard.

The **CHEM 400** casing usually of GRP construction. The GRP fans casing come with round straight outlet suitable for direct connection to flexible connector.

#### Radial Tip Backward Curve Impellers

Chemco fan impellers are of single inlet Single width (SISW) type. Impellers are of precision plastic injection moulded design with cast-in metal hub and mechanically welded to highest quality standard with excellent aerodynamic properties.

Impeller is usually of PP however, depending on the type of applications; impeller can be made of PA, PC, PVC or PVDF. Impeller can be thermoplastic material blended with composites to overcome high temperature, flame retardant resistant, ultraviolet or Electrostatic Discharge protection to suit customer's requirements. Each impeller is statically and dynamically balanced in two planes in accordance with Q2.5 of VDI 2060. The hubs are designed for use with taper-bushes and are made of high-grade cast plates to guarantee high reliability at the high peripheral speeds.

#### Fan Base and Support

The fan supporting steel stands and fan bases are manufactured from heavy gauge mild steel and have a zinc enriched primer applied finished UV stabilised top coat to provide maximum protection in the most adverse condition. Special surface treatment can be done on request. Fans can be rotated to suit different discharge directions.

### Antriebe

Genau gewuchtete Standard-Keilriemen-Scheiben mit Spannhülse, nach ISO 4183-1980. Alle Keilriemen entsprechend ISO 4148. Die Riementriebe werden entsprechend der benötigten Leistungen ausgewählt und korrekt verspannt was lange Standzeiten sicherstellt. Ventilatoren können in direkte und Riementrieb Regelungen.

### Motor

Je nach Anwendung sind Norm-Motoren von IP55 sind vorhanden, sondern auch andere Motoren auf Kundenwunsch geliefert werden.

Bei direktgetriebene Ventilatoren werden B5 Flansch-Motore eingebaut, für riemengetriebene Ventilatoren, B3 Fuß-Motore. Alle Motoren sind vollständig geschlossen und luftgekühlt und erfüllen BS 2613. Die Standard-Motoren sind einphasig/dreiphasig, 50/60 Hertz passend für 240/415 oder 230/400 Volt. Andere Spannungen sind auf Anfrage lieferbar.

### Tropenfestigkeit

Die Motor-Wicklungen sind mit Harz-Lacken ummantelt, welche den Motor passend für tropische Atmosphären machen. Zusätzlich Behandlungen können durchgeführt werden, wenn Motoren in extreme-tropischer Umgebung arbeiten sollen.

### Explosionsschutz

Alle Ventilatoren mit Ex-Motoren sind für die folgenden Bereiche zugelassen:

- 1) BS 4683 Part II zertifiziert für die Gruppen IIa und IIb
- 2) BS 4683 Part IV, mit EXE bezeichnet und passed zum Gebrauch in Bereichen der Zone 1 für die Gruppen IIa und IIb.
- 3) BS 5000 Part 16 und BS 4683 Part III, mit EXN bezeichnete Typen, passend zum Gebrauchen in Bereichen der Zone 2.

### Standard Farben

sämtliche PP - entsprechend PANTONE warm grau 1C,

sämtliche GFK - entsprechend PANTONE 430

Andere Farben wenn erforderliche.

### Sicherheitstechnische Besonderheiten

Sämtliche Riementriebe, Scheiben, vorstehend Stellschrauben, Keile und andere rotierende Teile haben Verkleidungen aus strapazierfähigem perforiertem Blech, um sicherheitstechnische Forderungen zu erfüllen. Jeder Ventilator hat ein festmontiertes Typenschild mit Seriennummer und Modellbezeichnung, Lüfter + Antriebsdaten, Luftmenge und Fabrikationsdatum.

### Zubehör

- Anbau von Feder-Schwingungsdämpfer
- Kondensatablaufstutzen mit Verschluß
- Motor, Motorschutz, Spanschlitten -Schienen, Riemenschutz, Riemenantrieb
- Lager, Abdeckung für Lager und Welle
- Ventilatorgrundrahmen
- Ansaugflansch, Ansaugmanschette mit Klemmband
- Splitter Schutzhaube.

### wahlweise

- andere Farbe aus der gesamten Farbpalette
- flammhemmend
- Hochtemperatur
- elektrostatische Entladung – Anti-statisch, statisch verlustbehaftet oder leitend
- UV-beständig

### Thermische und chemische Beständigkeit

Die Temperatur der Luft oder der Gase dürfen den für den Werkstoff angegebenen Wert nicht überschreiten:

Werkstoff	max. Temp. [°C]
PVC	60
PP	80
GFK	100
PVDF	120

Für ein ausführliche Liste der chemischen Anwendung wenden Sie sich bitte an unsere örtliche Vertretungen.

### Drives

Standard pulley drive with taper bush type, accurately balanced and conform to ISO 4183-1980 standards. All Vee belts are conform to ISO 4148. Belt section is selected with correct ratings and tensioning to ensure prolonged usage. Fans can be supplied in direct and belt drive arrangements.

### Motor

Depending on the application, standard electric driven motor of IP55 are fitted, but other rated motors to suit customer requirements can be supplied.

For direct driven fans, motor are usually of B5 flange mounting and for belt driven fans, motor are of B3 foot mounting. All motors are totally enclosed and fan cooled complying with BS 2613. The motors are single/three phase, 50/60 Hz suitable for 240/415 or 230/400 volts standards. All other voltage can be supplied upon request.

### Tropicalisation

Motor windings are coated with resin varnishes, which make the motor suitable for tropical atmospheres. Additional treatment can be carried out where motors are required to operate in severe tropical environments.

### Flameproof

All fans mounted with flameproof motors are suitable in the following areas:

- 1) BS 4683 Part II certified for Groups IIa and IIb.
- 2) BS 4683 Part IV designated EXE and are suitable for use in Zone 1 areas for group IIa and IIb.
- 3) BS 5000 Part 16 and BS 4683 Part III designated type EXN and suitable for use in Zone 2 areas.

### Standard Colour

All PP - Equivalent to PANTONE Warm Grey 1C,

All GRP - Equivalent to PANTONE 430

Other colour as optional required.

### Safety Features

All drive-belts, pulleys, projecting set screws, keys and other rotating parts have heavy-duty perforated sheet as protective guards to meet safety requirement. All fans are labelled with nameplate securely attached on each fan showing the serial and model number, fan & drive duties, rotation of flow and date of manufacture.

### Accessories

- Anti-vibration spring mounting
- Condense water drain socket and plug
- Motor, motor guard, slide rails, belt guard, belt drive
- Bearing, bearing and shaft cover
- Fan and motor support base frame
- Inlet flanges, Inlet sleeve with clamping bands
- Splinter protection cover.

### Optional

- Full range of colour matching
- Flame Retardant
- High Temperature
- Electrostatic Discharge – Anti-static, Static dissipative or Conductive
- Ultra Violet

### Thermal and Chemical resistant

The temperature of the air and gases must not exceed that specified for the materials:

Material	max. Temp. [°C]
PVC	60
PP	80
GRP	100
PVDF	120

Please contact our local sales engineers for detailed list of Chemical Application Information.

# CHEM 75R

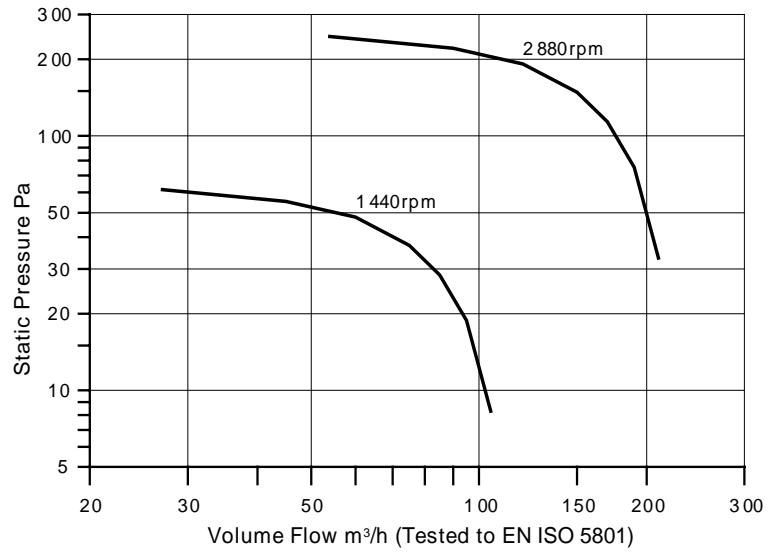

## Leistungsdaten / Performance Data

CHEM 75R		1440rpm	1440rpm	2880rpm	2880rpm
U	V	230	400	230	400
f	Hz	50	50	50	50
Phase	~	1	3	1	3
P	kW	0.05	0.05	0.11	0.11
I <sub>a</sub>	A	0.4	0.1	1.2	0.3
$\dot{V}_{max}$	m³/h	105	105	210	210
n	min <sup>-1</sup>	1440	1440	2880	2880
L <sub>w</sub>	dB(A)	34	34	48	48
△	Enclosure	TEFC	TEFC	TEFC	TEFC
	Service Factor	1.15	1.15	1.15	1.15
■	kg	5.2	5.2	5.2	5.2

## Abmessungen / Dimensional Data

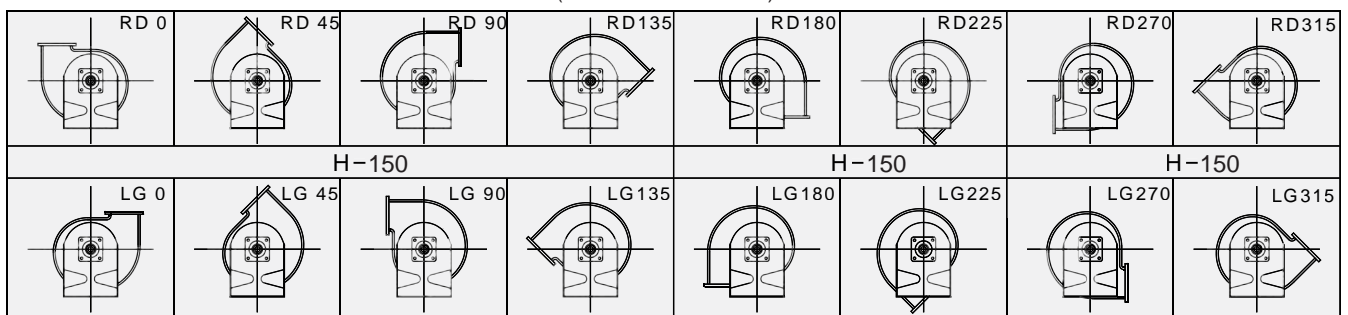
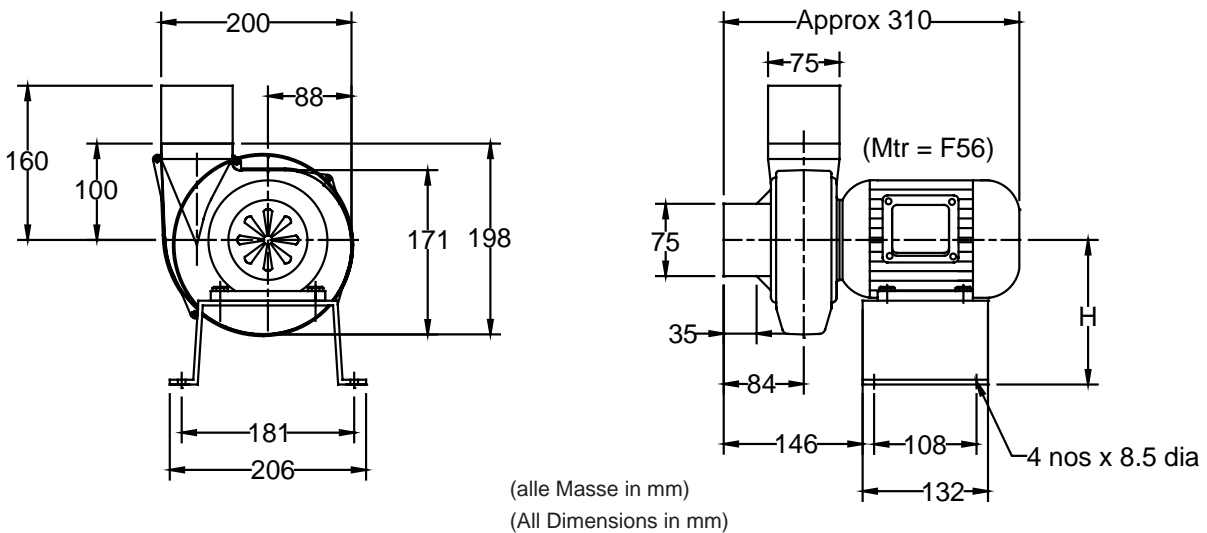

# CHEM 90R

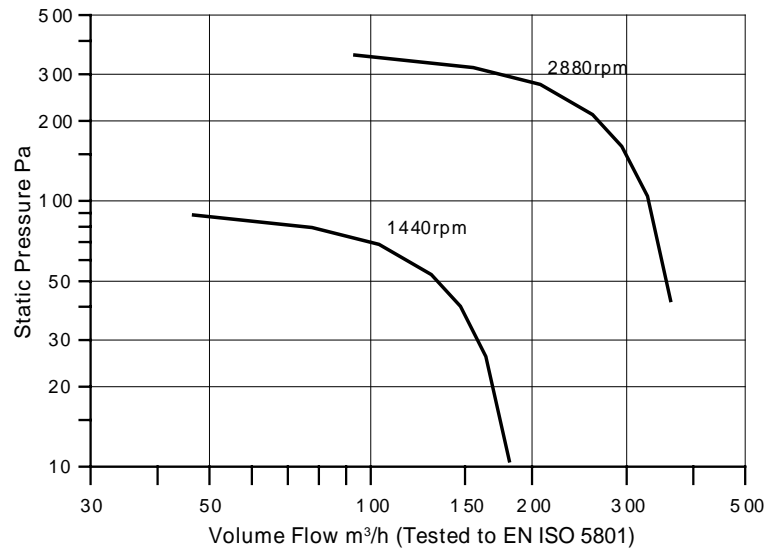

## Leistungsdaten / Performance Data

CHEM 90R		1440rpm	1440rpm	2880rpm	2880rpm
U	V	230	400	230	400
f	Hz	50	50	50	50
Phase	~	1	3	1	3
P	kW	0.05	0.05	0.11	0.11
I <sub>a</sub>	A	0.4	0.1	1.2	0.3
$\dot{V}_{max}$	m³/h	181	181	363	363
n	min <sup>-1</sup>	1440	1440	2880	2880
L <sub>w</sub>	dB(A)	37	37	51	51
△	Enclosure	TEFC	TEFC	TEFC	TEFC
Service Factor		1.15	1.15	1.15	1.15
■	kg	5.4	5.4	5.4	5.4

## Abmessungen / Dimensional Data

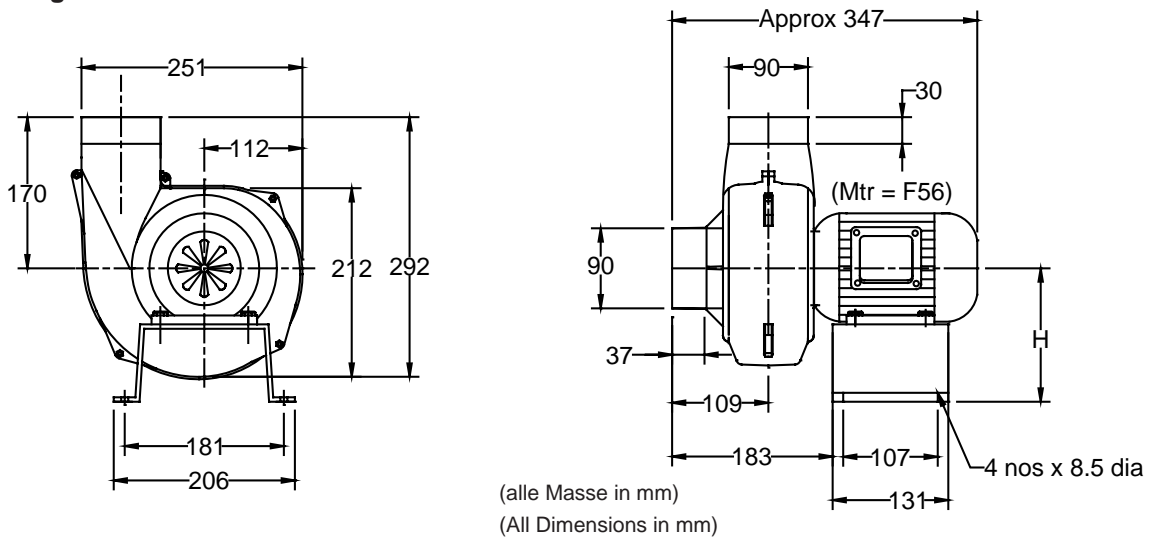

RD 0	RD 45	RD 90	RD 135	RD 180	RD 225	RD 270	RD 315
H - 150				H - 150		H - 150	
LG 0	LG 45	LG 90	LG 135	LG 180	LG 225	LG 270	LG 315

# CHEM 90FC

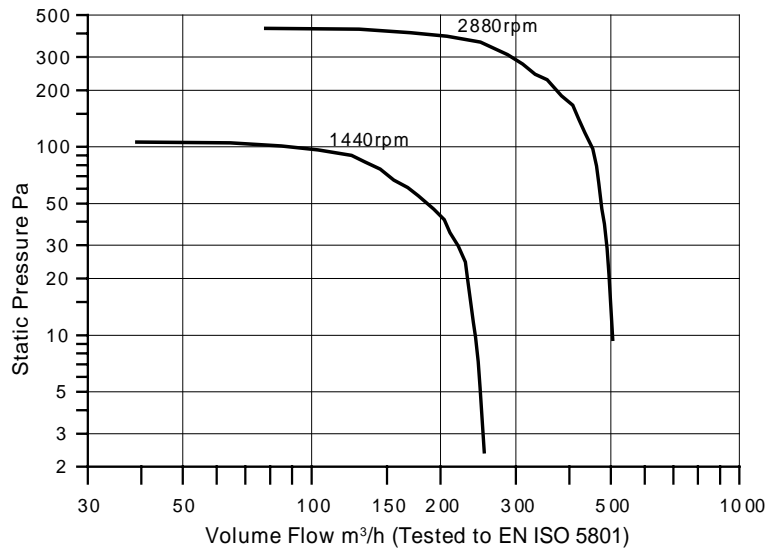

## Leistungsdaten / Performance Data

CHEM 90FC		1440rpm	1440rpm	2880rpm	2880rpm
U	V	230	400	230	400
f	Hz	50	50	50	50
Phase	~	1	3	1	3
P	kW	0.05	0.05	0.11	0.11
I <sub>a</sub>	A	0.4	0.1	1.2	0.3
$\dot{V}_{max}$	m³/h	256	256	511	511
n	min <sup>-1</sup>	1440	1440	2880	2880
L <sub>w</sub>	dB(A)	37	37	51	51
⚠	Enclosure	TEFC	TEFC	TEFC	TEFC
	Service Factor	1.15	1.15	1.15	1.15
■	kg	5.4	5.4	5.4	5.4

## Abmessungen / Dimensional Data

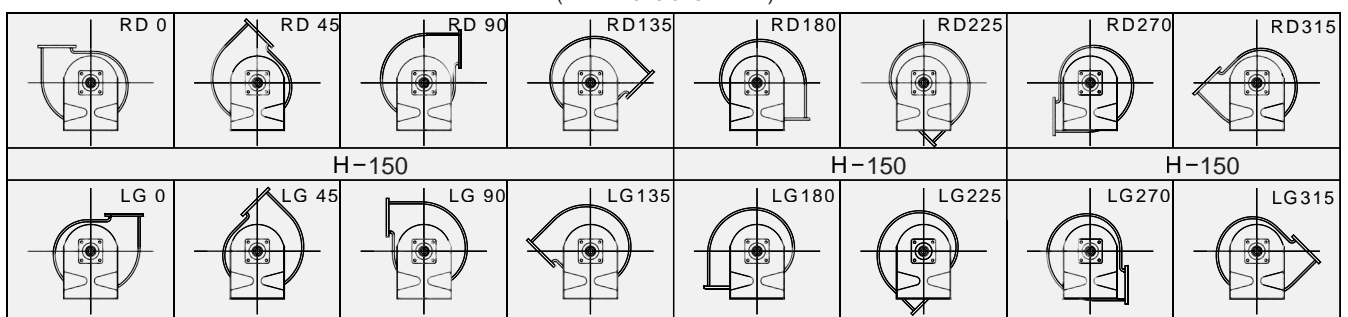
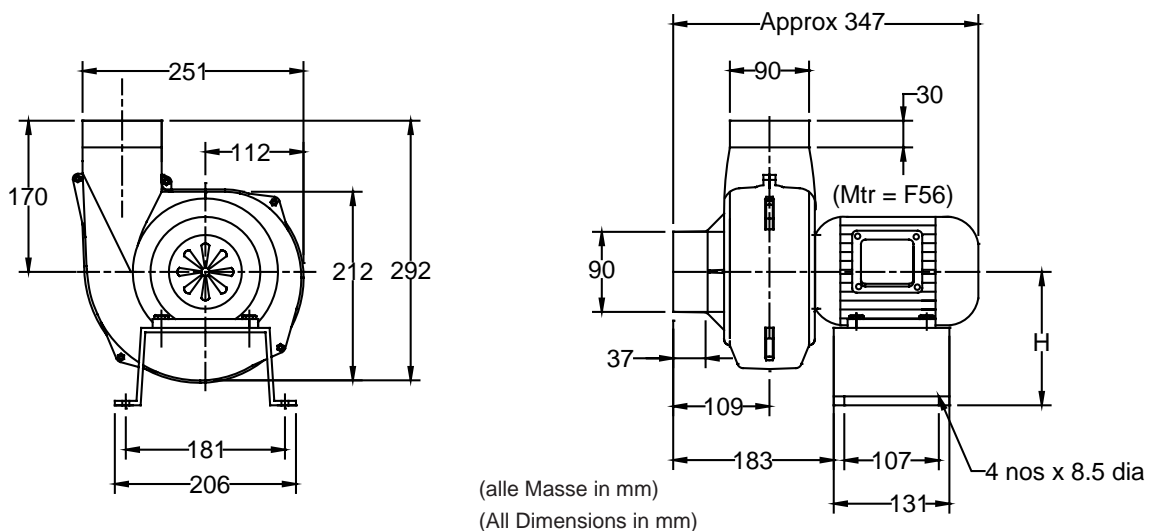



# CHEM 110FC

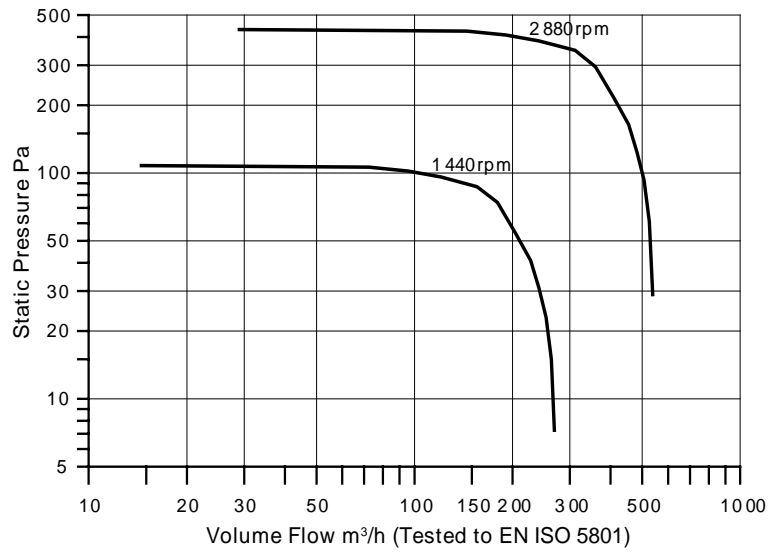

## Leistungsdaten / Performance Data

CHEM 110FC		1440rpm	1440rpm	2880rpm	2880rpm
U	V	230	400	230	400
f	Hz	50	50	50	50
Phase	~	1	3	1	3
P	kW	0.05	0.05	0.11	0.11
I <sub>a</sub>	A	0.4	0.1	1.2	0.3
$\dot{V}_{max}$	m³/h	279	279	558	558
n	min <sup>-1</sup>	1440	1440	2880	2880
L <sub>w</sub>	dB(A)	43	43	57	57
⚠	Enclosure	TEFC	TEFC	TEFC	TEFC
	Service Factor	1.15	1.15	1.15	1.15
📦	kg	5.6	5.6	5.6	5.6

## Abmessungen / Dimensional Data

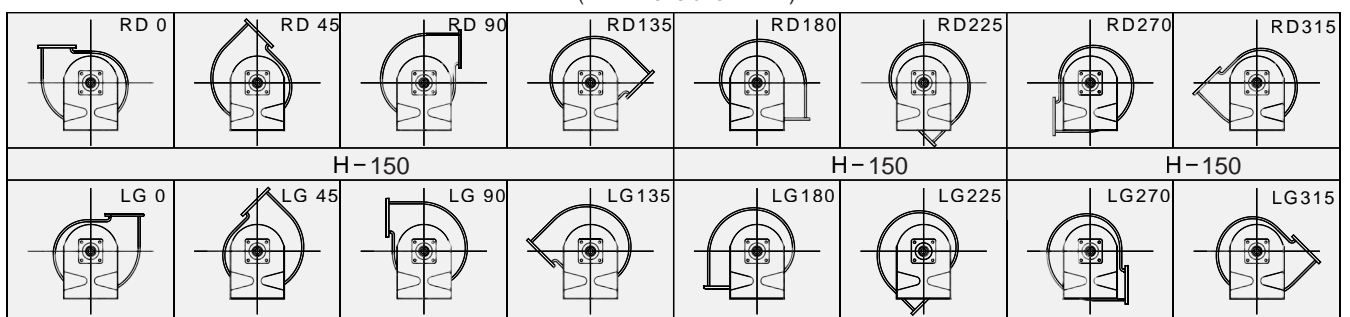
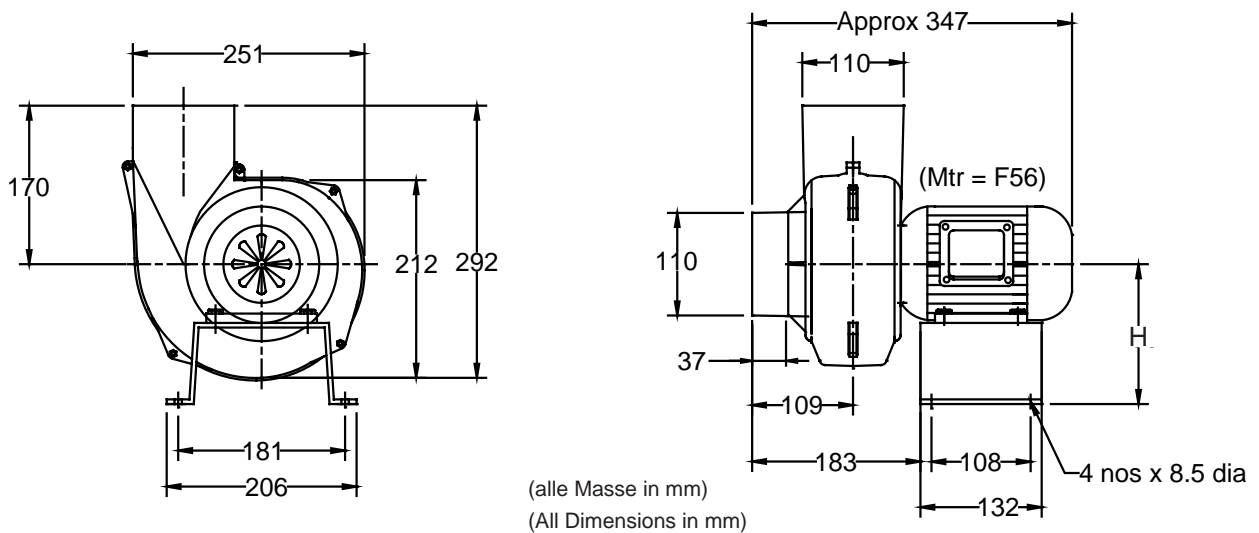

# CHEM 125

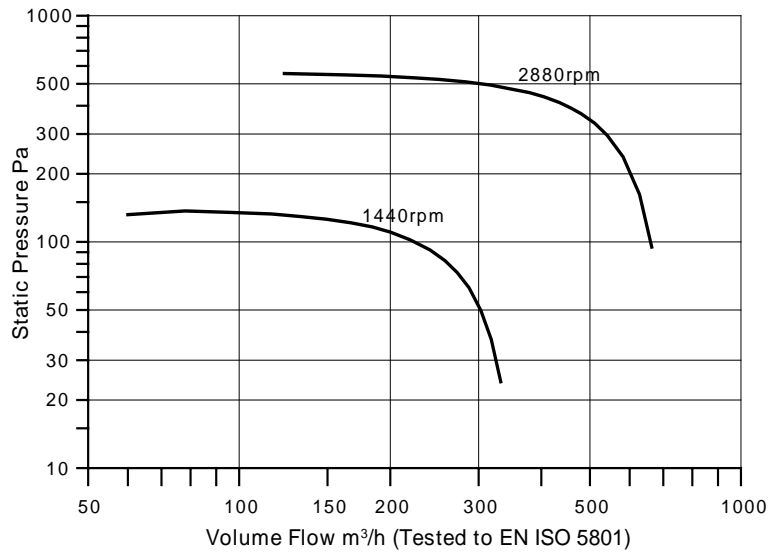

## Leistungsdaten / Performance Data

CHEM 125		1440rpm	1440rpm	2880rpm	2880rpm
U	V	230	400	230	400
f	Hz	50	50	50	50
Phase	~	1	3	1	3
P	kW	0.25	0.25	0.37	0.37
I <sub>a</sub>	A	2.4	0.64	3.6	0.88
$\dot{V}_{max}$	m³/h	333	333	664	664
n	min <sup>-1</sup>	1440	1440	2880	2880
L <sub>w</sub>	dB(A)	44	44	58	58
△	Enclosure	TEFC	TEFC	TEFC	TEFC
	Service Factor	1.15	1.15	1.15	1.15
■	kg	18	18	18	18

## Abmessungen / Dimensional Data

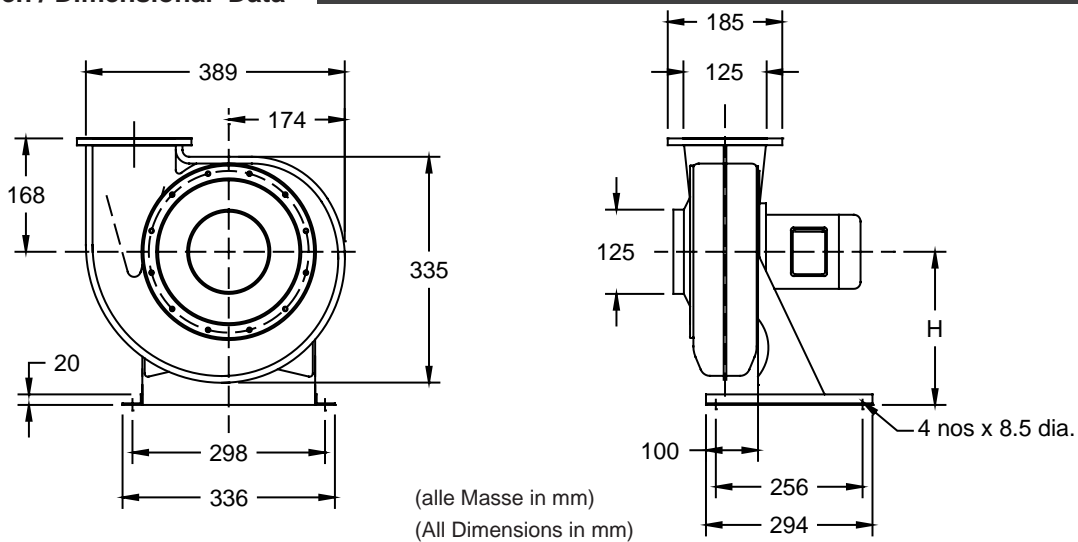

RD 0	RD 45	RD 90	RD 135	RD 180	RD 225	RD 270	RD 315
H-228				H-308		H-228	
LG 0	LG 45	LG 90	LG 135	LG 180	LG 225	LG 270	LG 315

# CHEM 160

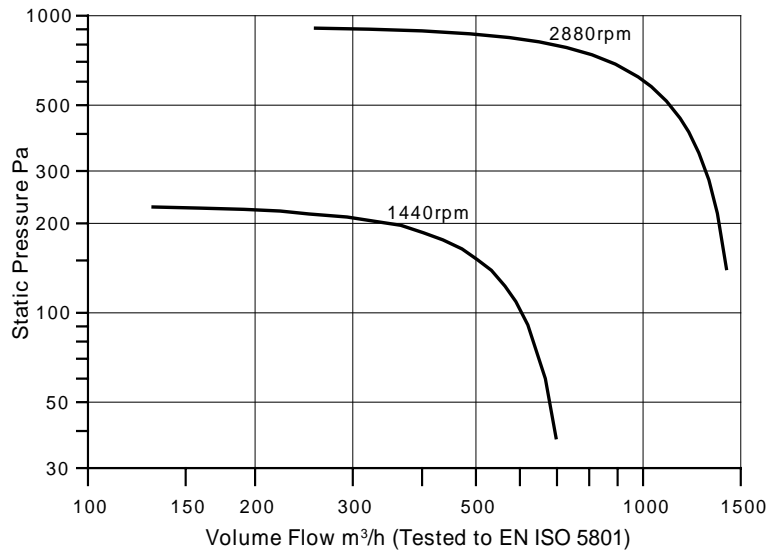

## Leistungsdaten / Performance Data

CHEM 160		1440rpm	1440rpm	2880rpm	2880rpm
U	V	230	400	230	400
f	Hz	50	50	50	50
Phase	~	1	3	1	3
P	kW	0.25	0.25	0.55	0.55
I <sub>a</sub>	A	1.6	0.64	4.5	1.4
$\dot{V}_{max}$	m³/h	696	696	1413	1413
n	min <sup>-1</sup>	1440	1440	2880	2880
L <sub>w</sub>	dB(A)	49	49	60	60
⚠	Enclosure	TEFC	TEFC	TEFC	TEFC
	Service Factor	1.15	1.15	1.15	1.15
■	kg	32	32	32	32

## Abmessungen / Dimensional Data

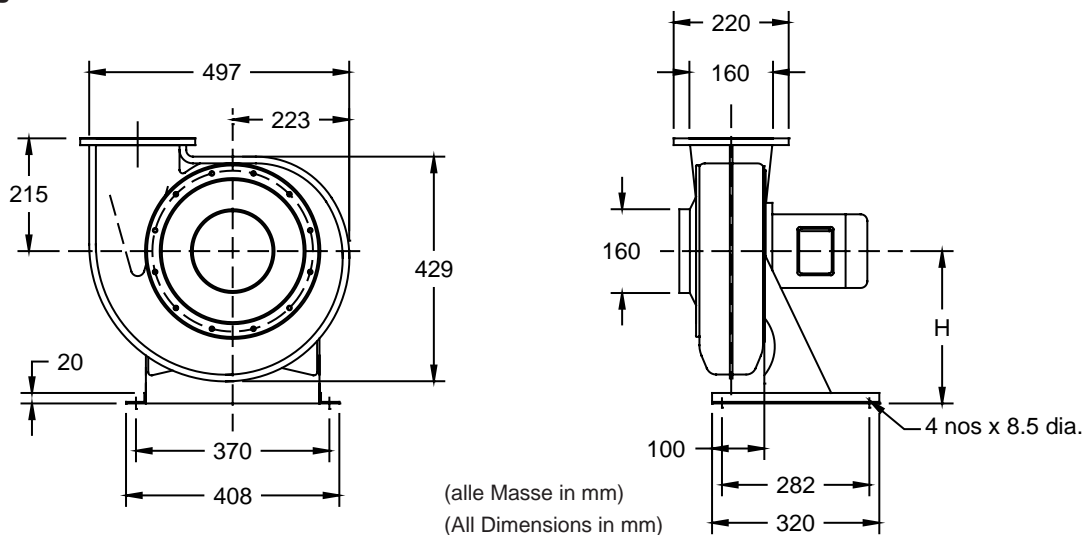

RD 0	RD 45	RD 90	RD 135	RD 180	RD 225	RD 270	RD 315
H-291				H-396		H-291	
LG 0	LG 45	LG 90	LG 135	LG 180	LG 225	LG 270	LG 315

# CHEM 180

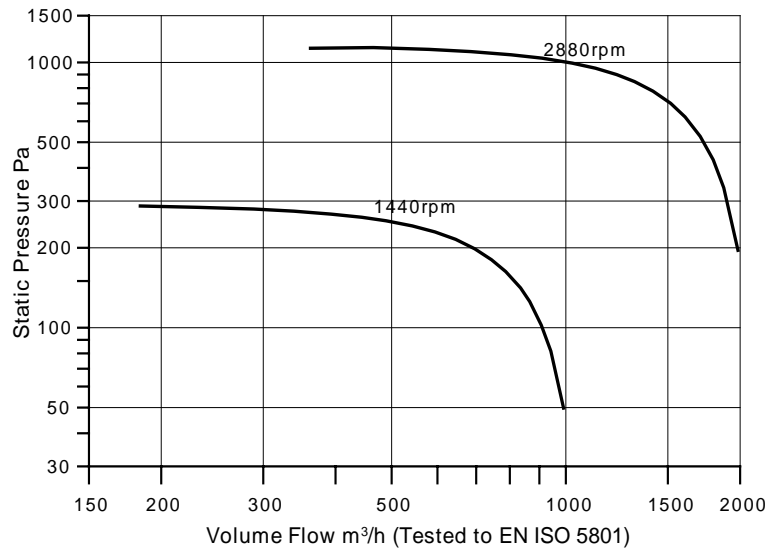

## Leistungsdaten / Performance Data

CHEM 180		950rpm	950rpm	1440rpm	1440rpm	2880rpm	2880rpm
U	V	230	400	230	400	230	400
f	Hz	50	50	50	50	50	50
Phase	~	1	3	1	3	1	3
P	kW	0.25	0.25	0.25	0.25	1.1	1.1
I <sub>a</sub>	A	2.6	0.73	2.4	0.64	9.5	2.46
$\dot{V}_{max}$	m³/h	650	650	991	991	1983	1983
n	min <sup>-1</sup>	950	950	1440	1440	2880	2880
L <sub>w</sub>	dB(A)	43	43	52	52	63	63
△	Enclosure	TEFC	TEFC	TEFC	TEFC	TEFC	TEFC
	Service Factor	1.15	1.15	1.15	1.15	1.15	1.15
■	kg	33	33	33	33	38	38

## Abmessungen / Dimensional Data

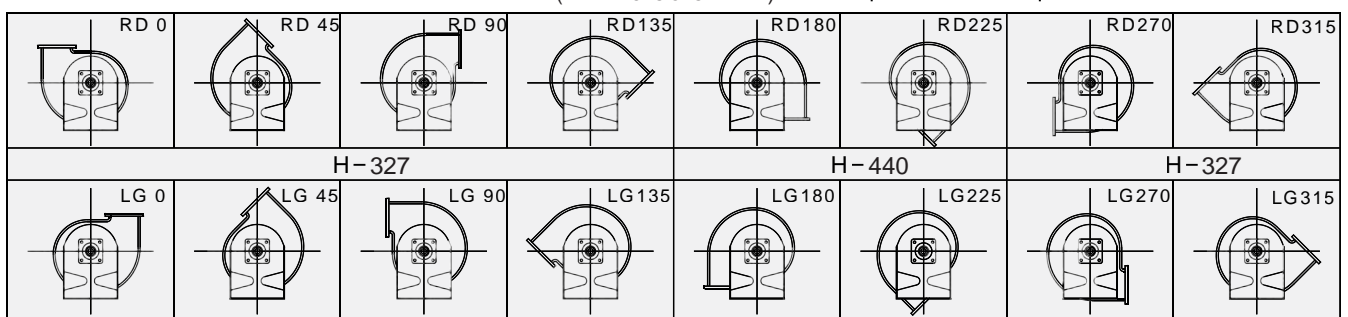
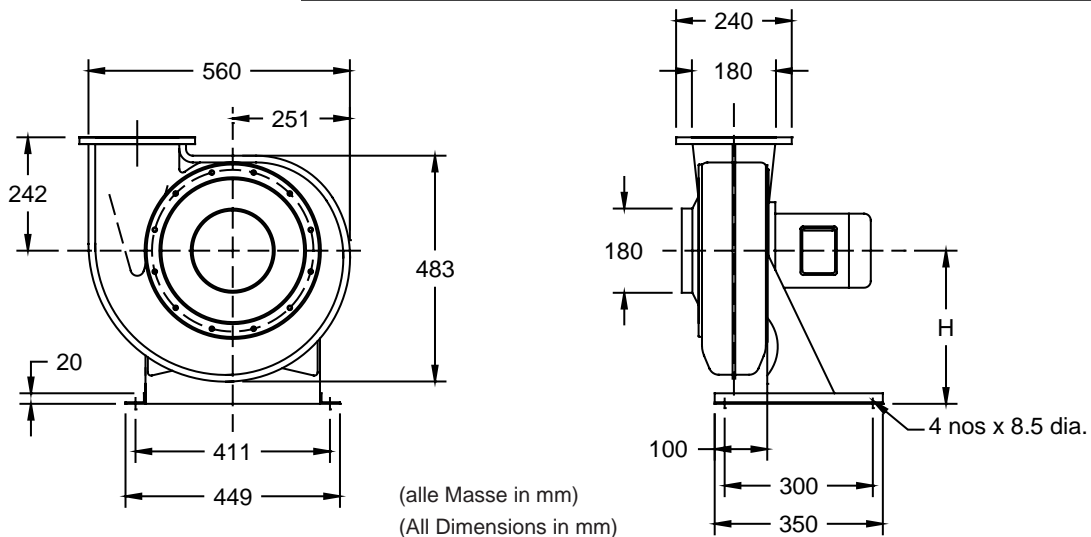

# CHEM 200

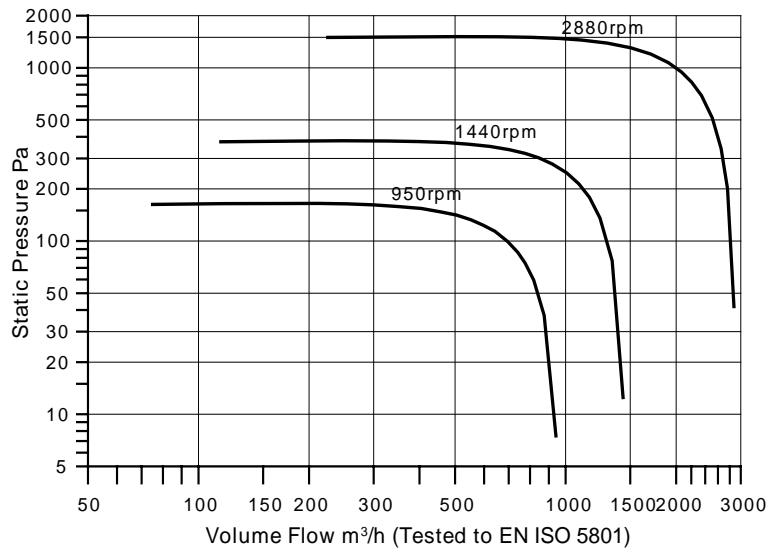

## Leistungsdaten / Performance Data

CHEM 200		950rpm	950rpm	1440rpm	1440rpm	2880rpm	2880rpm
U	V	230	400	230	400	230	400
f	Hz	50	50	50	50	50	50
Phase	~	1	3	1	3	1	3
P	kW	0.25	0.25	0.37	0.37	1.5	1.5
I <sub>a</sub>	A	2.6	1.27	3.2	1.21	11	3.18
$\dot{V}_{max}$	m³/h	950	950	1438	1438	2870	2870
n	min <sup>-1</sup>	950	950	1440	1440	2880	2880
L <sub>w</sub>	dB(A)	44	44	53	53	70	70
⚠	Enclosure	TEFC	TEFC	TEFC	TEFC	TEFC	TEFC
	Service Factor	1.15	1.15	1.15	1.15	1.15	1.15
■	kg	34	34	34	34	43	43

## Abmessungen / Dimensional Data

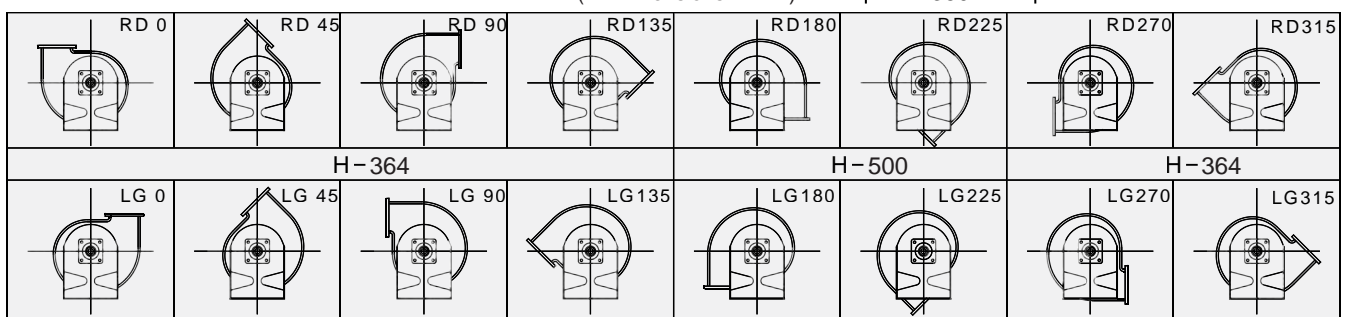
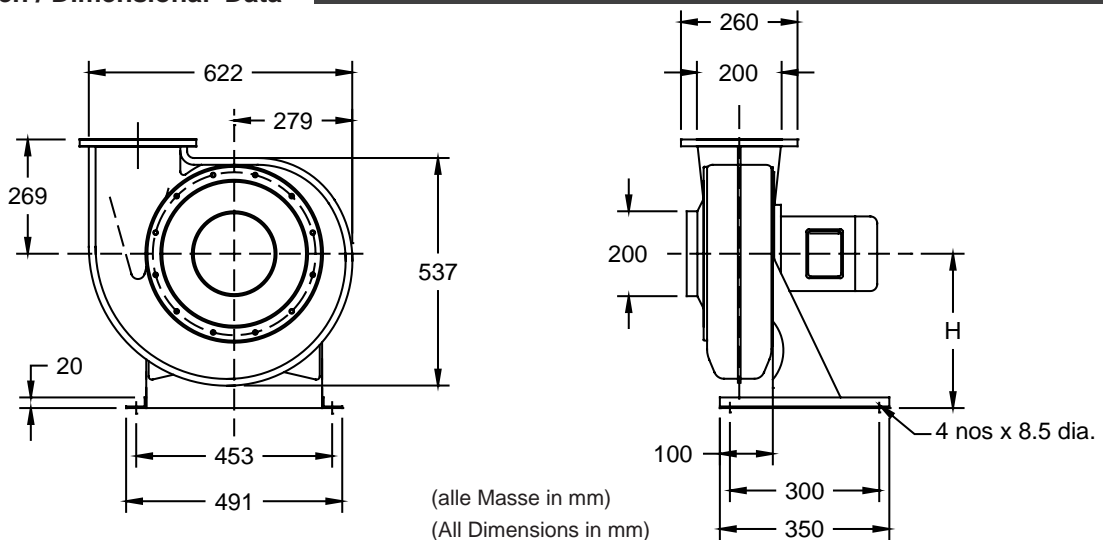

# CHEM 250

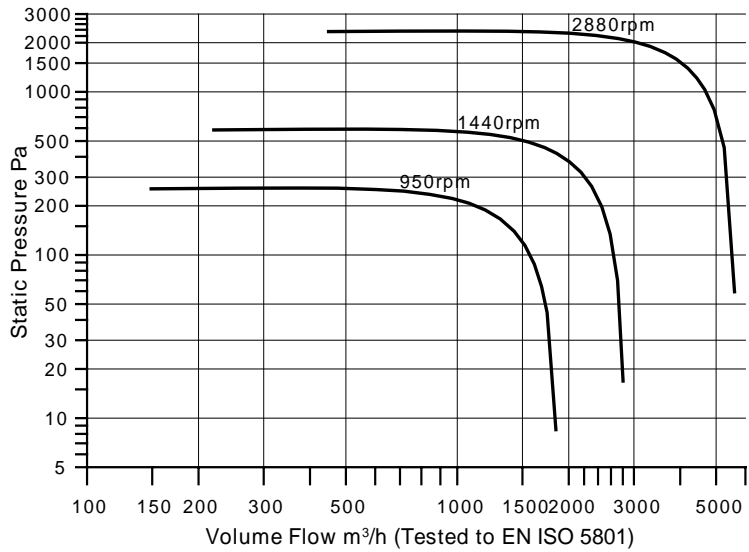

## Leistungsdaten / Performance Data

CHEM 250		950rpm	950rpm	1440rpm	1440rpm	2880rpm	2880rpm
U	V	230	400	230	400	400	400
f	Hz	50	50	50	50	50	50
Phase	~	1	3	1	3	3	3
P	kW	0.37	0.37	0.75	0.75	4.0	5.5
I <sub>a</sub>	A	3.5	1.27	5.6	1.99	7.36	11.1
$\dot{V}_{max}$	m³/h	1849	1849	2804	2804	3930	5609
n	min <sup>-1</sup>	950	950	1440	1440	2880	2880
L <sub>w</sub>	dB(A)	50	50	62	62	73	73
⚠	Enclosure	TEFC	TEFC	TEFC	TEFC	TEFC	TEFC
	Service Factor	1.15	1.15	1.15	1.15	1.15	1.15
■	kg	38	38	38	38	50	58

## Abmessungen / Dimensional Data

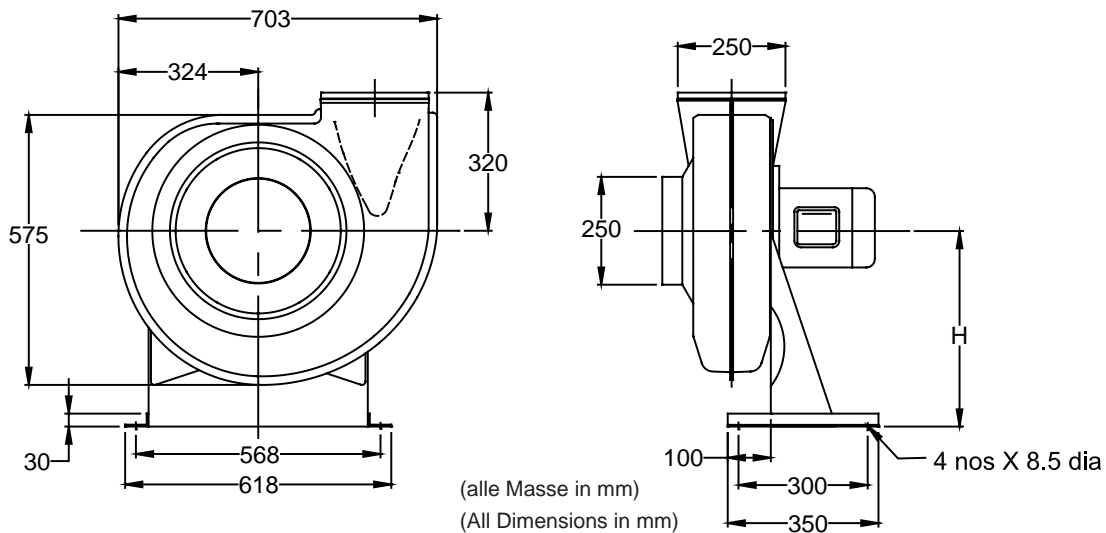

H - 454				H - 633		H - 454	

# CHEM 315

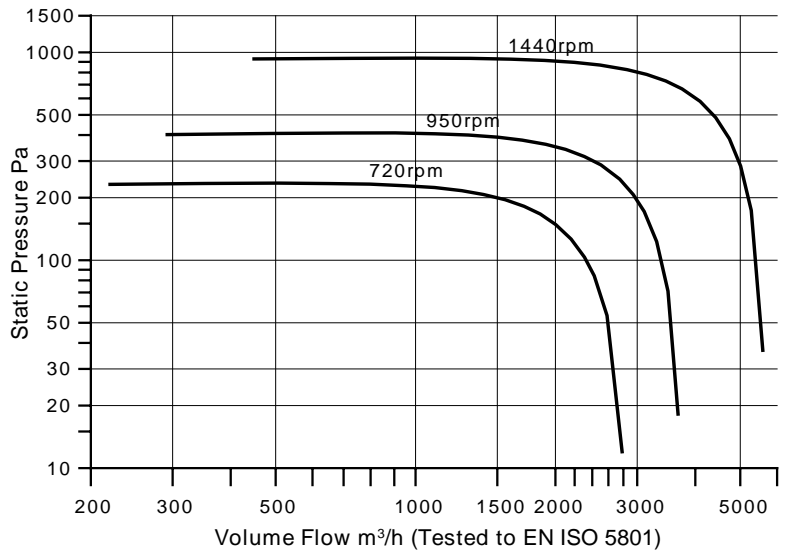

## Leistungsdaten / Performance Data

CHEM 315		720rpm	950rpm	950rpm	1440rpm	1440rpm	1440rpm	1440rpm
U	V	400	230	400	230	400	230	400
f	Hz	50	50	50	50	50	50	50
Phase	~	3	1	3	1	3	1	3
P	kW	0.37	0.75	0.75	1.5	1.5	2.2	2.2
I <sub>a</sub>	A	1.42	6	2.16	10.5	3.66	14.5	5.08
$\dot{V}_{max}$	m³/h	2804	3699	3699	4000	4000	5609	5609
n	min <sup>-1</sup>	720	950	950	1440	1440	1440	1440
L <sub>w</sub>	dB(A)	52	58	58	67	67	67	67
⚠	Enclosure	TEFC	TEFC	TEFC	TEFC	TEFC	TEFC	TEFC
	Service Factor	1.15	1.15	1.15	1.15	1.15	1.15	1.15
■	kg	61	61	61	66	66	78	78

## Abmessungen / Dimensional Data

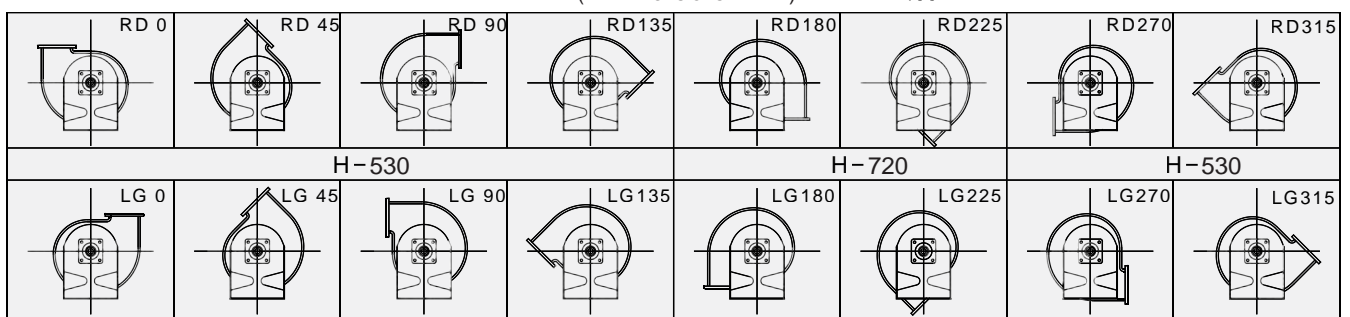
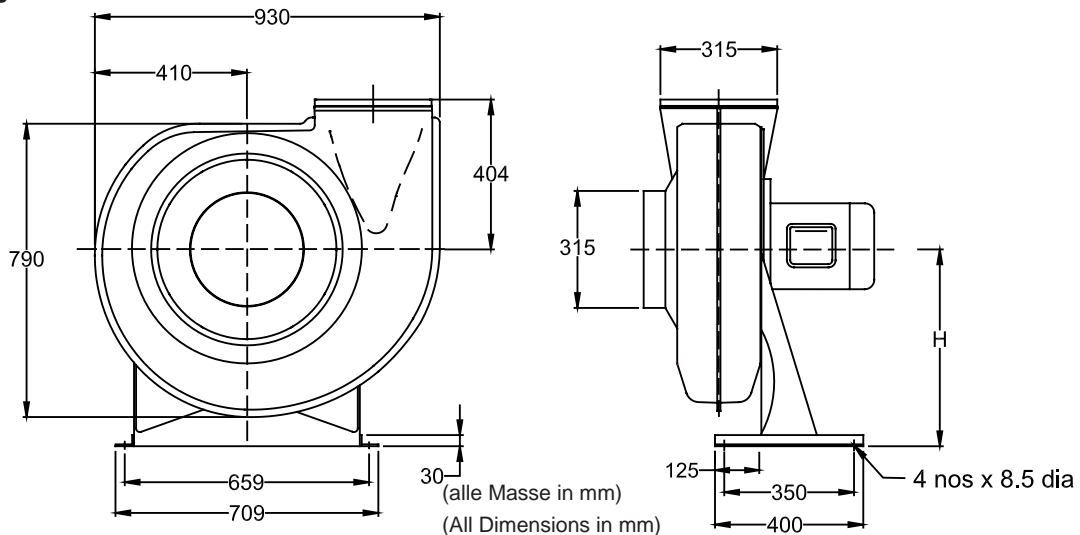

# CHEM 400

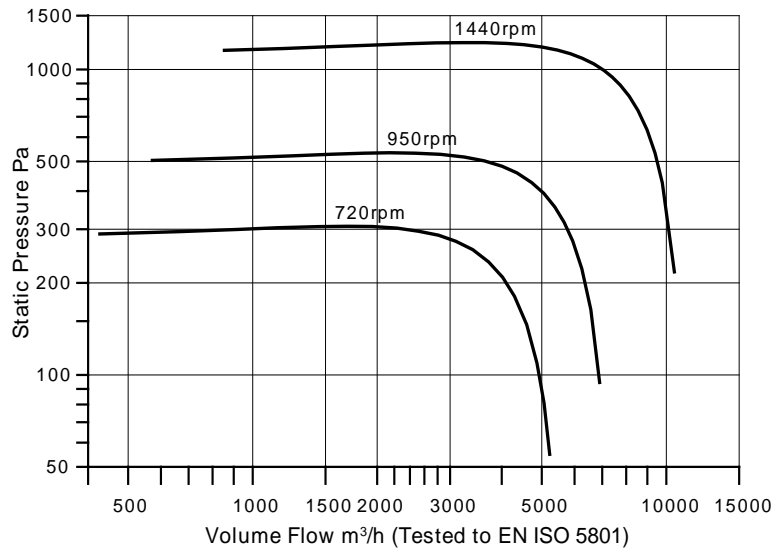

## Leistungsdaten / Performance Data

CHEM 400		720rpm	950rpm	950rpm	950rpm	950rpm	950rpm	1440rpm	1440rpm	1440rpm
U	V	400	230	400	230	400	400	400	400	400
f	Hz	50	50	50	50	50	50	50	50	50
Phase	~	3	1	3	1	3	3	3	3	3
P	kW	0.75	1.1	1.1	1.5	1.5	2.2	4.0	5.5	7.5
I <sub>a</sub>	A	2.53	7.2	3.31	10	4	5.53	8.03	12	15.2
$\dot{V}_{max}$	m³/h	5225	3400	3400	5520	5520	6900	4972	9215	10450
n	min <sup>-1</sup>	720	950	950	950	950	950	1440	1440	1440
L <sub>w</sub>	dB(A)	61	67	67	67	67	67	73	73	73
⚠	Enclosure	TEFC	TEFC	TEFC	TEFC	TEFC	TEFC	TEFC	TEFC	TEFC
	Service Factor	1.15	1.15	1.15	1.15	1.15	1.15	1.15	1.15	1.15
■	kg	95	90	90	98	98	106	108	127	142

## Abmessungen / Dimensional Data

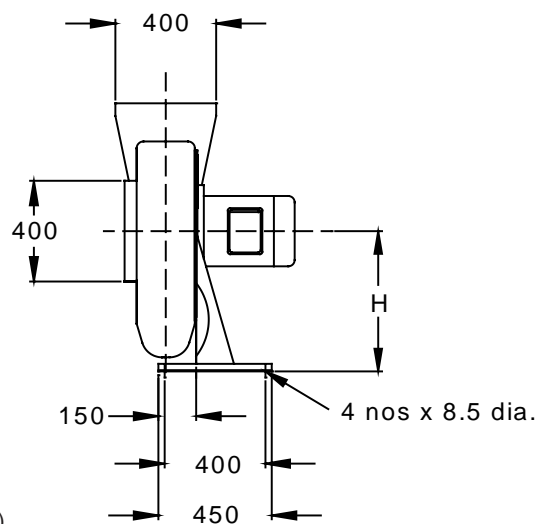
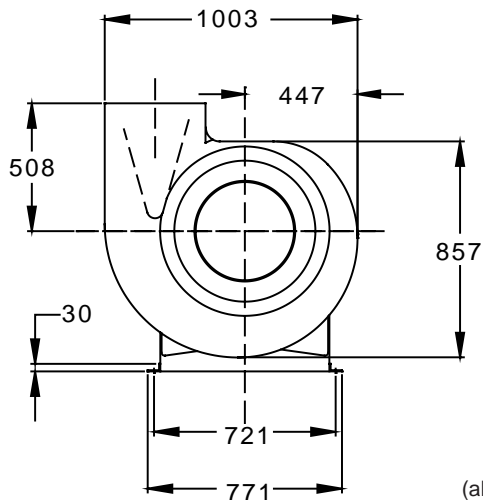

(alle Masse in mm)  
(All Dimensions in mm)

RD 0	RD 45	RD 90	RD 135	RD 180	RD 225	RD 270	RD 315
H - 557				H - 750		H - 557	
LG 0	LG 45	LG 90	LG 135	LG 180	LG 225	LG 270	LG 315



# Auf-und Einbau Assembly and mounting

## CHEM 75 to 110DD

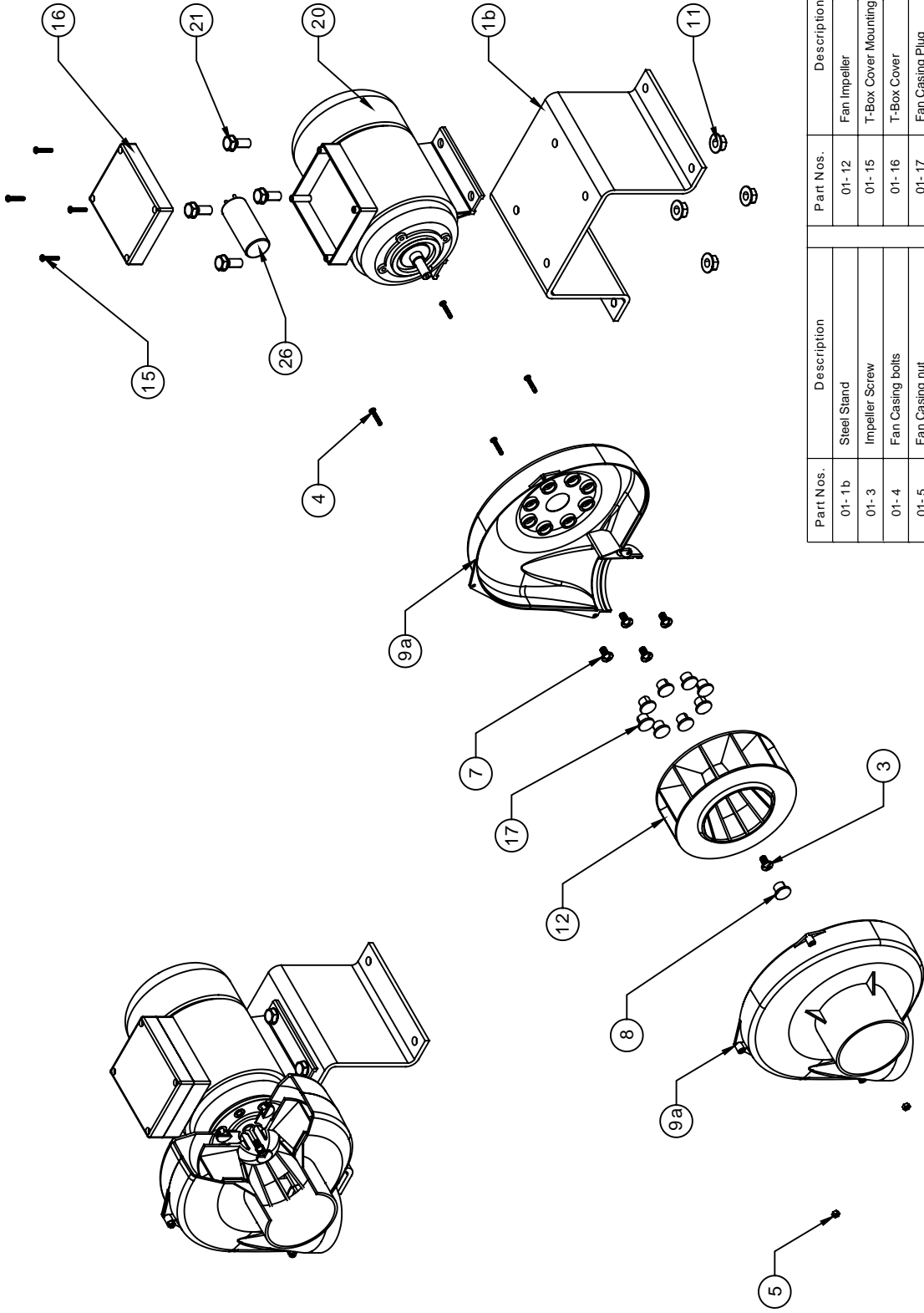

Part Nos.	Description	Part Nos.	Description
01-1b	Steel Stand	01-12	Fan Impeller
01-3	Impeller Screw	01-15	T-Box Cover Mounting Screw
01-4	Fan Casing bolts	01-16	T-Box Cover
01-5	Fan Casing nut	01-17	Fan Casing Plug
01-7	Fan Casing Screw	01-20	Electric Motor
01-8	Impeller Plug	01-21	Steel Stand Screw and Wash
01-9a	Fan Casing (PP Type)	01-26	Capacitor
01-11	Steel Stand nut		

# Auf-und Einbau

## Assembly and mounting



### CHEM 125 to 200DD

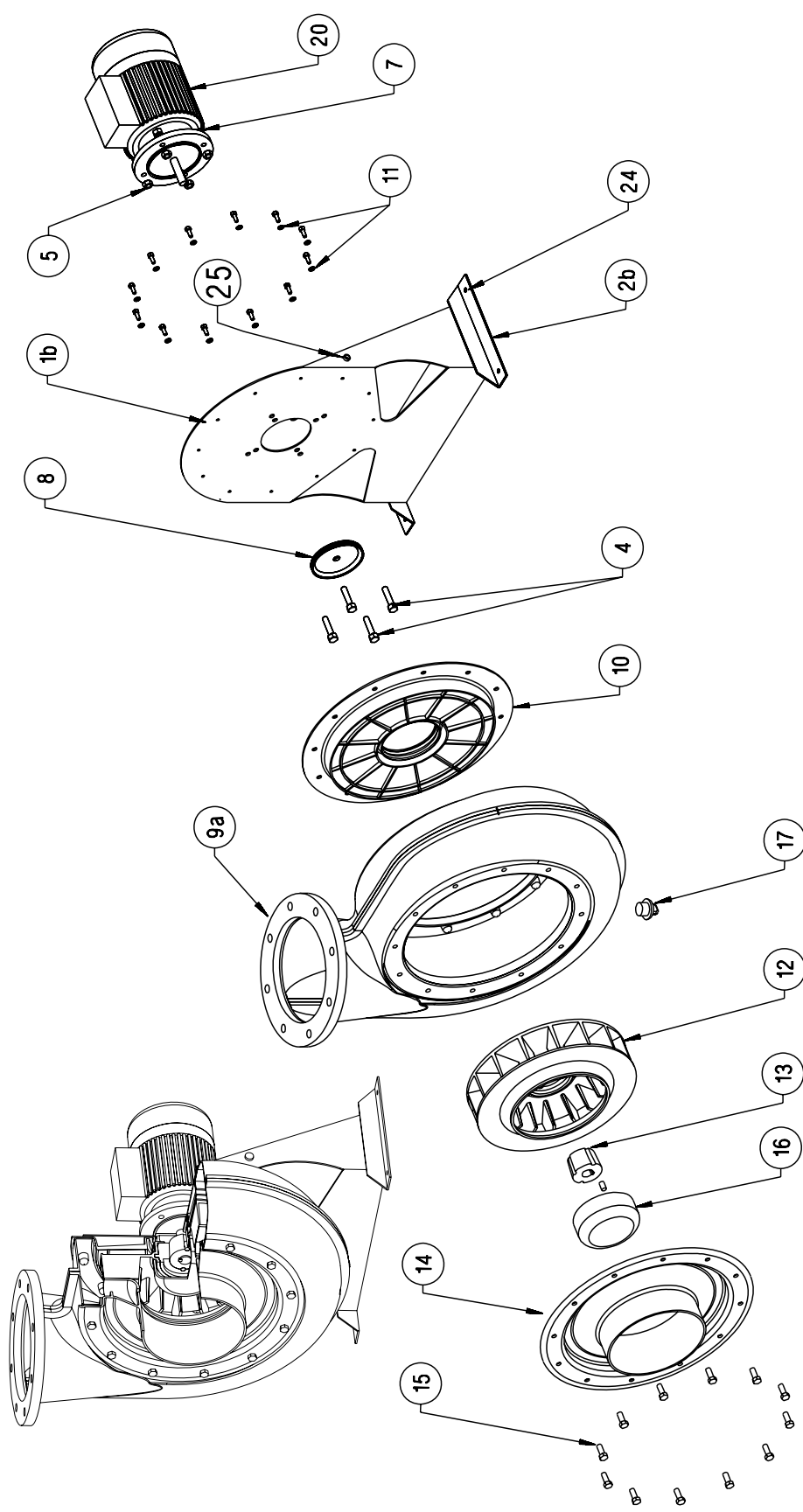

Part Nos	Beschreibung	Description	Part Nos	Beschreibung	Description
01-1b	Stählerner Bock	Steel Stand	01-12	Ventilatorlaufrad	Fan impeller
01-2b	Grundrahmen für Direktantrieb	Base for direct drive	01-13	Taper-Bushes	Taper-Bushes
01-4	Sechskantschrauben	Hexagonal bolts	01-14	Gehäuseeinlaufdeckung	Casing inlet cover
01-5	Sechskantmuttern	Hexagonal nuts	01-15	Schrauben	Bolts
01-7	Federringe und Muttern	Spring washers and nuts	01-16	Laufradwellenabdeckung	Impeller Cap
01-8	Gummidichtung	Rubber Gasket	01-17	Kondensatablaufverschluss	Drain plug
01-9a	Ventilatorgehäuse (PP type)	Fan casing (PP type)	01-20	Elektromotor	Electric motor
01-10	Gehäuserückschiebe	Casing back cover	01-24	Montageposition der Federschwingsdämpfer	Spring Isolator mounting position
01-11	Unterlegscheiben und Muttern	Washers and nuts	01-25	Kranösen	Hoisting holes

# Auf-und Einbau Assembly and mounting

## CHEM 250 to 315DD

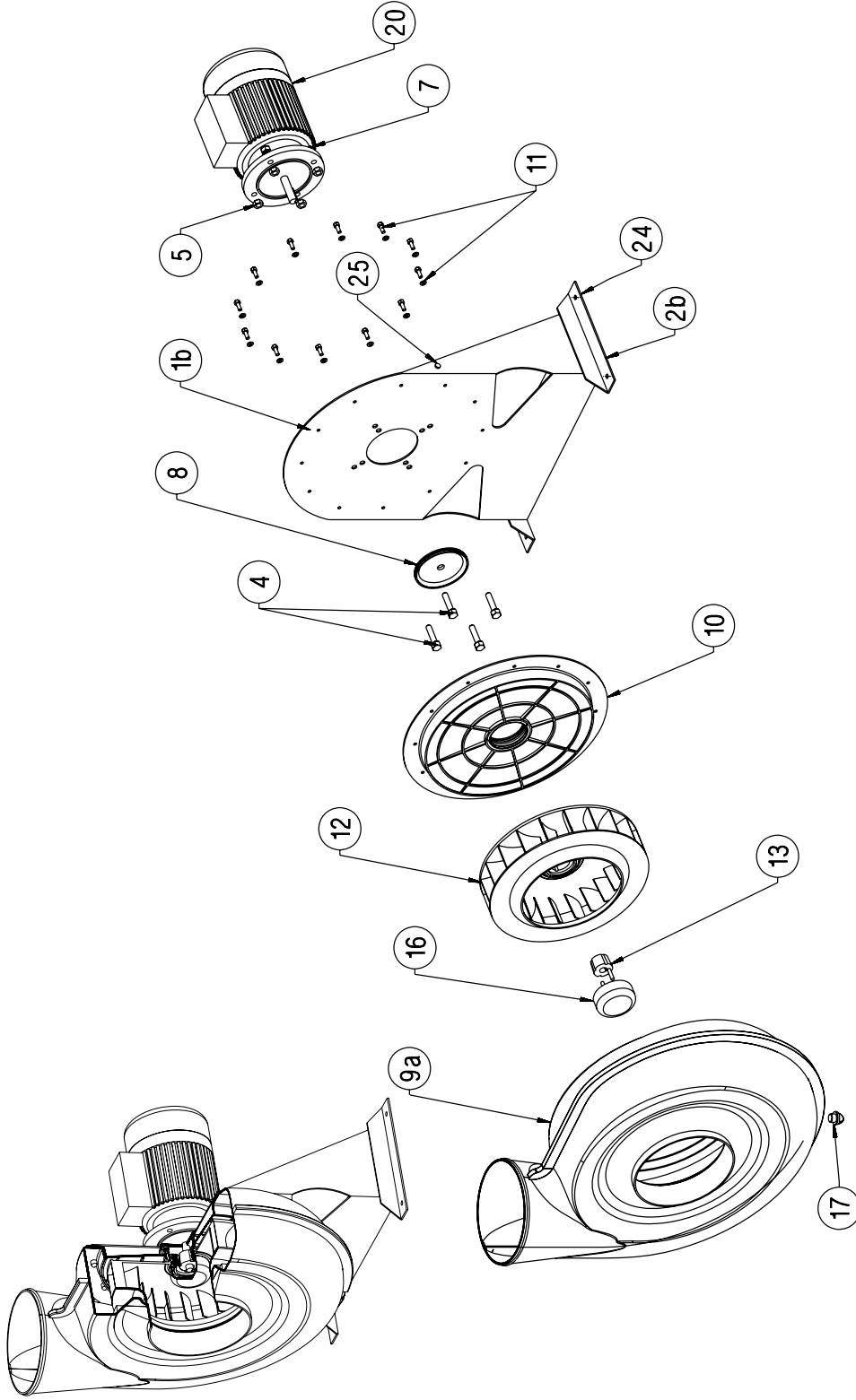

Part Nos	Beschreibung	Description	Part Nos	Beschreibung	Description
01-1b	Stählerner Bock	Steel Stand	01-11	Unterlegscheiben und Muttern	Washers and nuts
01-2b	Grundrahmen für DirektantriebFan	Base for direct drive	01-12	Ventilatorlaufrad	Fan impeller
01-4	Sechskantschrauben	Hexagonal bolts	01-13	Taper-Buchse	Taper-Bushes
01-5	Sechskantmuttern	Hexagonal nuts	01-16	Laufradwellenabdeckung	Impeller Cap
01-7	Federlinge und Muttern	Spring washers and nuts	01-17	Kondensatablauverschluß	Drain plug
01-8	Gummidichtung	Rubber Gasket	01-20	Elektromotor	Electric motor
01-9a	Ventilatorgehäuse (PP type)	Fan casing (PP type)	01-24	Montageposition der Federschwingungsdämpfer	Spring Isolator mounting position
01-10	Gehäuserückschiebe	Casing back cover	01-25	Kranösen	Hoisting holes

**Auf-und Einbau**  
*Assembly and mounting*



**CHEM 400DD**

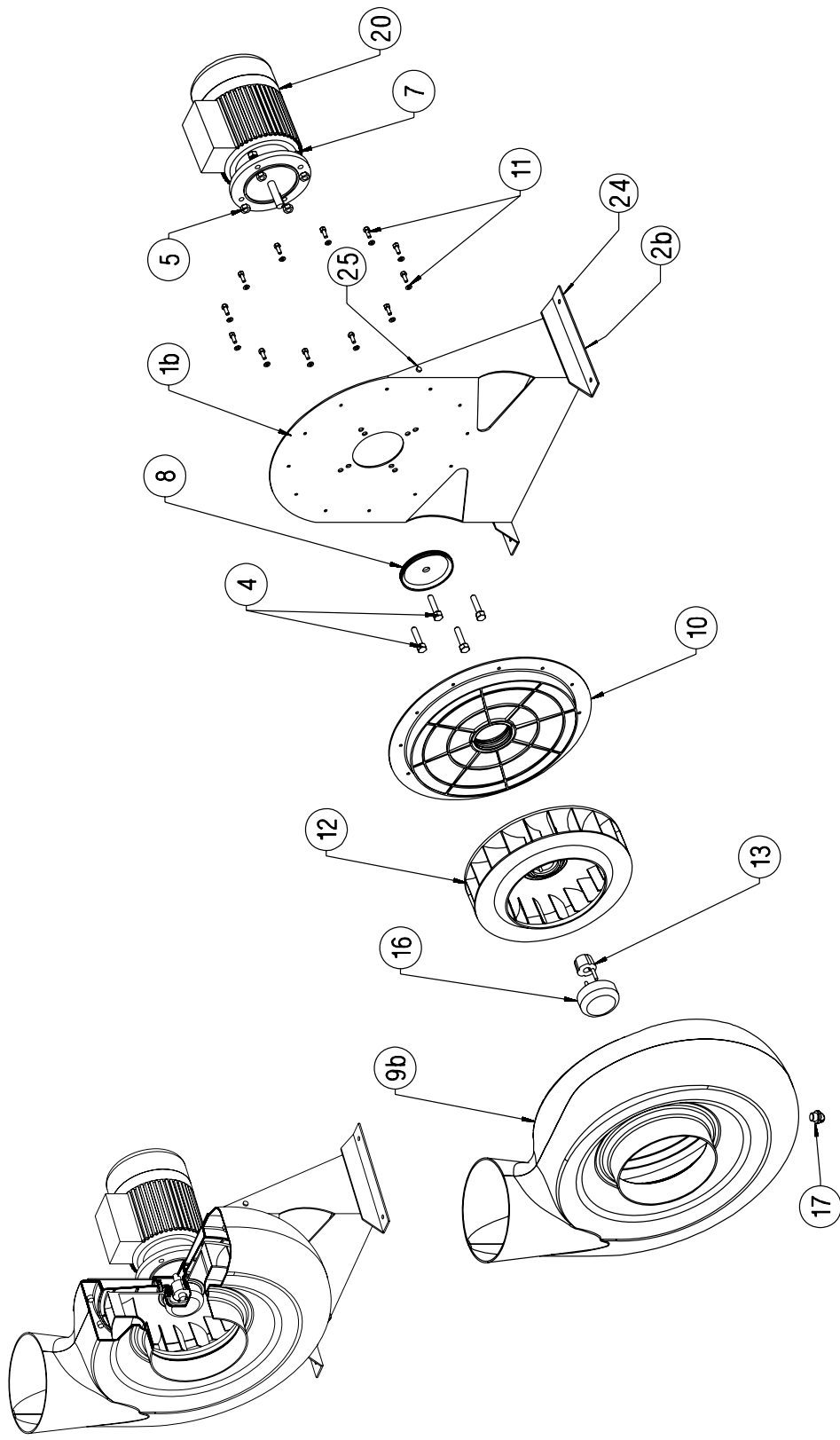

Part Nos	Beschreibung	Description	Part Nos	Beschreibung	Description
01-1b	Stählerner Bock	Steel Stand	01-11	Unterlegscheiben und Muttern	Washers and nuts
01-2b	Grundrahmen für DirektantriebFan	Base for direct drive	01-12	Ventilatorlaufrad	Fan impeller
01-4	Sechskantschrauben	Hexagonal bolts	01-13	Taper-Buchse	Taper-Bushes
01-5	Sechskantmuttern	Hexagonal nuts	01-16	Laufwellenabdeckung	Impeller Cap
01-7	Federringe und Muttern	Spring washers and nuts	01-17	Kondensatablaufverschluss	Drain plug
01-8	Gummidichtung	Rubber Gasket	01-20	Elektromotor	Electric motor
01-9b	Ventilatorgehäuse (GFK type)	Fan casing (GRP type)	01-24	Montageposition der Federschwungsdämpfer	Spring Isolator mounting position
01-10	Gehäuserückschiebe	Casing back cover	01-25	Kranösen	Hoisting holes



# Johndec Engineering Plastics

## Moulded Fittings & Pipes

Johndec moulded fittings are seamless moulded and are segment free, the fittings can contain both gaseous, abrasive and corrosive media. The Johndec moulded fittings are offered at the standard tube nominal diameters and can be manufactured with pipe connections; bushing connection and flanged connections. Standard extruded pipe is also available to suit the fittings.

## Range Of Use

The Johndec-moulded fittings are suitable for assembling in pipelines in which gaseous, abrasive and corrosive media are transported. As materials for the Johndec-moulded fittings, different thermo-plastics stand with different and maximally permissible thermal loads for the selection.

PVC	Polyvinyl chloride	RAL7011	(Iron grey)
PVC-C (CORZAN)	Chloridized polyvinyl chlorid	US Norm 215 resp.245	(Grey)
PP	Polypropylene	RAL 7032	(Silicic grey)
PPs	Polypropylene (flame resistant)	RAL 7037	(Dust grey)
PE	Polyethylene		(Black)
PP-el-s (PPs-el)	Polypropylene flame-retardant, electrically conductive		(Black)
PVDF	Polyvinylidene fluoride		(Nature)

- Pipework • Bends • Connecting Pieces • T-Pieces • Final Cover • Branches • Connecting Sleeves
- Twin Sleeves • Air Grilles • Reducer • Flanges • Silencers • Cows • Dampers



## Europe

### Germany

Ing. Günther Rößler  
D-07619 Schkölen  
Tel. (+49) 03 66 94 / 22 359  
Fax (+49) 03 66 94 / 22 357  
guenther.roessler@wolterfans.de

Mattias Industrievertretungen  
D-16259 Bad Freienwalde  
Tel. (+49) 033 44 / 30 1994  
Fax (+49) 033 44 / 30 1996  
thomas.mattias@wolterfans.de

Industrieservice Drexler  
D-49080 Osnabrück  
Tel. (+49) 0 541 / 20 04 88 3  
Fax (+49) 0 541 / 20 04 88 4  
wolfgang.drexler@wolterfans.de

Burkhardt Projekt GmbH  
D-67583 Guntersblum  
Tel. (+49) 0 62 49 / 82 01  
Fax (+49) 0 62 49 / 88 58  
info@bp-wolter.de

Friedrich Glock  
D-97980 Bad Mergentheim  
Tel. (+49) 0 79 31 / 37 44  
Fax (+49) 0 79 31 / 28 58  
friedrich.glock@wolterfans.de

### Danmark:

Air-Con Danmark A/S  
DK-8400 Ebeltoft  
Tel. (+45) 086 / 34 51 11  
Fax (+45) 086 / 34 58 10  
jbj@air-con.dk

### Hungary:

Air-Technik Légtechnikai Kft.  
HU-2040 Budaörs  
Tel. (+36) 023 / 42 85 33  
Fax (+36) 023 / 42 85 44  
bp.air-technik@trogas.hu

### Ireland:

Finheat Ltd.  
IE-Dublin 12, Walkinstown  
Tel. (+353) 01 / 45 64 066  
Fax (+353) 01 / 45 64 071  
sales@finheat.com

### Lithuania:

JSC Saldos Prekyba  
LT-78109 Siauliai  
Tel. (+37) 041 / 54 02 12  
Fax (+37) 041 / 59 61 76  
prekyba@saldas.lt

### Netherlands:

AirFan B. V.  
NL-7442 CX Nijverdal  
Tel. (+31) 054 / 83 66 366  
Fax (+31) 054 / 83 65 320  
ventilatie@airfan.nl

Rucon B. V. Ventilatoren  
NL-3840 AG Harderwijk  
Tel. (+31) 034 / 14 11 670  
Fax (+31) 034 / 14 11 690  
verkoop@rucon.nl

### Österreich:

Wolter-Werksvertretung Österreich  
A-4040 Linz  
Tel. (+43) 0 732 / 75 77 07  
Fax (+43) 0 732 / 75 77 07 75  
wolter.linz@aon.at  
Poland:

Wentoprodukt  
44-100 Gliwice  
Tel. (+48) 32 331-34-24  
Fax (+48) 32 729-76-53  
biuro@wentoprodukt.pl

### Portugal:

Safe Park Ventilação Industrial Lda.  
P-2675-240 Odiveelas  
Tel. (+351) 21 93 / 75 265  
Fax (+351) 21 93 / 86 061  
safepark@netcabo.pt

### Russia:

Euroclimat-Prof  
RU-107082 Moskau  
Tel. (+7) 4 95 / 97 57 530  
Fax (+7) 4 95 / 97 57 530  
gso@euroclimat.ru

### Schweiz:

Anson AG Zürich  
CH-8055 Zürich  
Tel. (+41) 04 / 46 11 111  
Fax (+41) 04 / 46 13 111  
info@anson.ch

Ventra Technik AG  
CH-8599 Salsmäsach  
Tel. (+41) 071 / 46 11 447  
Fax (+41) 071 / 46 11 448  
ventra@bluewin.ch

### Turkey:

Air Trade Centre Ltd Sti Türkiye,  
TR-34418 Seyrantepe / Istanbul  
Tel. (+90) 0212/2834 510  
Fax (+90) 0212/2783 964  
atc.turkey@airtradecentre.com

### United Kingdom:

Wolter UK Ltd.  
GB-B37 7UQ Solihull  
Tel. (+44) 0 121 / 63 55 390  
Fax (+44) 0 121 / 63 55 391  
info@wolteruk.com

## Middle East and North Africa

### Egypt:

Tiba Engineering Industries Co.  
Nasr City, Cairo  
Tel. (+2) 02 / 40 22 866  
Fax (+2) 02 / 40 22 771  
tibaengineering@manz-group.com

### Israel:

Ecopal Ltd.  
Hamasser 17, Qiryat Byalik Haifa, Israel  
Tel. (+972) 048 / 75 8117  
ecopal@zahav.net.il

### United Arab Emirates, Kuwait, Lebanon:

Wolter Ventilation LLC  
Energy International  
PO. Box 3562 Sharjah, UAE  
Tel. (+971) 06 / 53 43 477  
Fax (+971) 06 / 53 43 756  
energysh@emirates.net.ae

## Asia

### China Mainland:

Wolter Chemco Ventilation Ltd.  
Dongguan, Guangdong  
Tel. (+86) 769 / 8655 7298  
Fax (+86) 769 / 8655 7278

### Hongkong:

Wolter Asia Ltd.  
Hong Kong  
Tel. (+852) 24 / 56 01 98  
Fax (+852) 24 / 56 02 90  
info@chemco.com.hk

### Indonesia:

Pt. Sinarbaskara Triutama  
ID-10440 Jakarta Indonesia  
Tel. (+62) 0 21 / 31 00 191  
Fax (+62) 0 21 / 39 12 693  
sinarbaskara@cbn.net.id

### Korea:

Kaceco Wolter  
Kyonggido, Korea  
Tel. (+82) 0 31 / 3 5 0 3 0 2 2  
Fax (+82) 0 31 / 3 5 0 3 0 3 0  
wolter@kaceco.com

### Singapore:

Chemco Pte. Ltd.  
Techplace 1, Singapore 569738  
Tel. (+65) 0 63 / 52 95 48  
Fax (+65) 0 63 / 52 95 47  
twchui@singnet.com.sg

### Malaysia

Vibrant Marketing(M) Sdn Bhd.  
Tel. (+603) 7 8 47 35 00  
Fax (+603) 7 8 47 33 80  
vibrant@time.net.my

### Taiwan:

Waxlink International Co.,Ltd.  
Taipei, Taiwan  
Tel. (+886) 0 2 / 8932 1196  
Fax (+886) 0 2 / 8932 1197  
waxlink.tech@msa.hinet.net

### Thailand, Vietnam, Cambodia, Laos :

Wolter (Thailand) Ltd.  
Samutsakorn Thailand 74130  
Tel. (+66) 2 8 1 0 2 0 0 0  
Fax (+66) 2 8 1 0 2 2 9 9  
wolter\_thailand@hotmail.com

## Australia

### Perth:

Johndec Engineering Plastics PTY LTD.  
45 Attwell Street  
Landsdale 6065, Western Australia  
Tel. (+618) 9409 1789  
Fax (+618) 9309 1206  
engineer@johndecplastics.com.au  
www.johndecplastics.com.au



**Australian Distributor**

**Johndec Engineering Plastics PTY LTD**

Tel. (+618) 9409 1789 Fax (+618) 9309 1206 engineer@johndecplastics.com.au www.johndecplastics.com.au